

tolleranza alla sabbia 300 g/m³ - sand tolerance 300 g/m³

PANELLI®

italian excellence since 1906

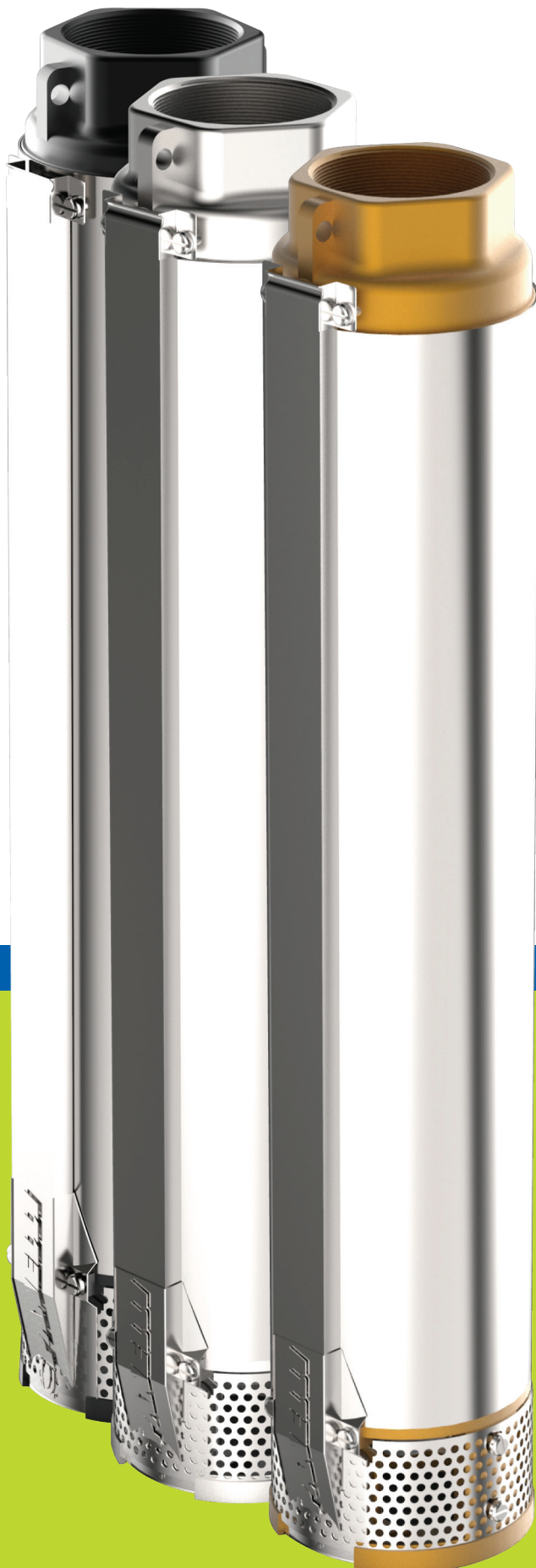

4" 95 PR
95 PRX | **50**Hz
95 PRG

**POMPA SOMMERSA
GIRANTE FLOTTANTE
SUBMERSIBLE PUMP
FLOATING IMPELLER**



MADE IN ITALY



maximum
300 g/m³

4" 95 PR
95 PRX | **50Hz**
95 PRG

POMPA SOMMERSA GIRANTE FLOTTANTE  *Patented*
SUBMERSIBLE PUMP FLOATING IMPELLER

Girante Flottante Brevettata

Floating Impeller Patented

Brevet Roue Flottante

Rodete Flotante Patentado

Assemblaggio robotizzato

Robotized assembly

Assemblage robotisé

Montaje robotizado

Massimo contenuto di sabbia: 300 gr/m³

Maximum sand content: 300 gr/m³

Tolérance de sable maximum: 300 gr/m³

Maxima cantidad de arena: 300 gr/m³

 **PANELLI**®

italian excellence since 1906

Tolleranze secondo UNI ISO 9906 livello 3B - Tolerances according to UNI ISO 9906 grade 3B

tolleranza alla sabbia 300 g/m³ - sand tolerance 300 g/m³

PANELLI®

italian excellence since 1906

4" 95 PR
95 PRX | **50Hz**
95 PRG

POMPA SOMMERSA GIRANTE FLOTTANTE
SUBMERSIBLE PUMP FLOATING IMPELLER



Diffusore in Noryl - Girante in Policarbonato

Noryl Diffuser - Polycarbonate Impeller

Diffuseur en Noryl - Roue en Polycarbonate

Difusor en Noryl - Rodete en Polycarbonate

Elemento e Camicia in AISI 304

Internal element and pump sleeve in Stainless Steel AISI 304

Élément intermédiaire et chemise en acier inoxydable AISI 304

Elemento intermedio y camisa en acero inoxidable AISI 304

95 PR

Aspirazione e mandata in ottone

Suction cage and delivery bowl in brass

Cage d'aspiration et refoulement en laiton

Cuerpo de aspiracion y de impulsión en bronce

95 PRX

Aspirazione e mandata in acciaio inossidabile

Suction cage and delivery bowl in Stainless Steel AISI 304

Cage d'aspiration et refoulement en acier inoxydable AISI 304

Cuerpo de aspiracion y de impulsión en acero inoxidable AISI 304

95 PRG

Aspirazione e mandata in ghisa con trattamento di cataforesi

Suction cage and delivery bowl cast iron with ced (cathode electro deposition)

Cage d'aspiration et refoulement en fonte avec cataphorèse

Cuerpo de aspiracion y de impulsión en hierro fundido con cataforesis

95 PR



95 PRX



95 PRG



4" 3

4"

95 PR
95 PRX
95 PRG

PANELLI®



ELETTROPOMPE SOMMERSE INTUBATE 4" (SERIE 95 PR N/95 PRX N / 95 PRG N)

Idonee al pompaggio di acqua pulita (T. max 35°C) in impianti di pressurizzazione, antincendio ed irrigazione, approvvigionamento idrico, ad uso civile ed industriale. Sono le più piccole della vasta gamma di pompe sommerse PANELLI e riassumono 40 anni di esperienza nella progettazione idraulica di elettropompe.

Il concetto innovativo (brevettato) della girante flottante a rasamento frontale facilita il flusso dell'acqua nella pompa con importanti vantaggi idraulici e funzionali.

VANTAGGI

Massimo rendimento, elevata resistenza all'usura da sabbia

l'ottima qualità dei materiali ed il concetto costruttivo aumenta notevolmente la durata della pompa - riduzione al minimo della manutenzione

MATERIALI

Materiali in esecuzione standard sono: Girante in tecnopolimero (Lexan) diffusore in tecnopolimero (Noryl GFN2) Elemento intermedio in acciaio Inox AISI 304 - Camicia esterna in acciaio inox AISI 304 Mandata e gabbia di aspirazione in ottone o acciaio inox - valvola di ritegno in acciaio inox AISI 304 incorporata. Inoltre, in aggiunta ai materiali della costruzione di serie, le pompe possono essere fornite con mandata e aspirazione in acciaio inox microfuso AISI 304 (SERIE 95 PRX), mandata e gabbia di aspirazione in ghisa con trattamento di cataforesi (SERIE 95 PRG)

CAMPI DI PRESTAZIONE IDRAULICHE

Portate fino a 24 m³/h (con serie elevata portata) Prevalenze fino a 470 m Potenze fino a 10 HP (7,5 Kw)

Massima quantità di sabbia ammessa: 300g/m³ serie 95 PR / 95 PRX / 95 PRG (Serie Elevata portata max 50g/m³, 95 REC - 95 SX - 95 PR 18- 95 PRX 18 - 95 PRG 18).



ELECTRIC SUBMERSIBLE PUMPS CASED VERSION 4" (SERIES 95 PR N/95 PRX N / 95 PRG N)

Pumps suitable for clean water supply (max. water temp. 35°C) for domestic and industrial applications such as pressure boosters, firefighting systems and irrigation.

The submersible pumps series 95 PR N / 95 PRX N 95 PRG N are the smallest in the wide range of submersible pumps manufactured by PANELLI and summarize 40 years experience in hydraulics. The patented know-how of the floating impeller with front shim adjustment enhances the water flow into the pump with important hydraulic and functional advantages.

ADVANTAGES

- High Efficiency

- High wear resistance to sand

- Longer pump life thanks to the high quality of materials and to the specific floating impeller design

- Very low maintenance need

MATERIALS

The materials of standard execution are: Impeller in technopolymer (Lexan) Diffuser in technopolymer (Noryl GFN2) Intermediate casing in Stainless Steel AISI 304 External sleeve in Stainless Steel AISI 304. Delivery bowl and suction cage in brass or stainless steel. Non return valve in Stainless Steel AISI 304 included. Besides standard construction the pumps can be manufacture with the Delivery Bowl and suction cage in casted stainless steel AISI 304 (SERIES 95 PRX), suction cage and delivery bowl in cast iron with CED (cathodo electro deposition) (SERIE 95 PRG).

HYDRAULIC PERFORMANCES

Capacity up to 24 m³/h with the unique High Capacity Series (95 PR 18, 95 PRX 18, 95 PRG 18, 95 REC 18, 95 SX18). Head up to 470 m Power range up to 7,5 kW-10HP.

Maximum sand content 300 g/m³ of water (High Capacity Series max 50 g/m³ of water, 95 REC - 95 SX - 95 PR 18, 95 PRX 18, 95 PRG 18).



ELECTROPOMPES IMMERGEES TUBEE 4" (SERIES 95 PR N/95 PRX N /95 PRG N)

Pompes pour eaux claires (Temp. Maxi de l'eau: 35°C) dans toutes applications domestiques et industrielles : surpression, pompes d'incendie, irrigation.

Les électropompes immergées série 95 PR N / P5 PRX N / 95 PRG N sont les plus petites de la large gamme des immergées produites par la PANELLI.

Le concept innovateur (Breveté) de la roue flottante favorise le flux de l'eau dans la pompe avec importants avantages hydrauliques et de fonctionnement.

ADVANTAGES

- Haut rendement
- Résistance élevée à l'abrasion du sable
- Durée de vie très importante grâce à la qualité des matériaux et à la conception de la roue flottante
- Manutention réduite

MATERIAUX

Les matériaux d'exécution standard sont: Roue en technopolymère (Lexan) Diffuseur en technopolymère (Noryl GFN2) Élément intermédiaire en Acier Inoxy AISI 304 Chemise de blocage en acier inox AISI 304. Pièce de refoulement et cage d'aspiration en laiton ou acier inoxydable. Clapet de retenue en acier INOX AISI 304 incorporé. Outre aux matériaux de construction de série, les pompes peuvent être fournies avec des pièces de refoulement et cages d'aspiration en micro-fusion acier INOX AISI 304 (SERIES 95 PRX), pièces de refoulement et cages d'aspiration en fonte avec cataphoreèse (95 PRG).

PERFORMANCES HYDRAULIQUES

Débit jusqu'à 24 m³/h avec la série High Capacity (95 PR 18, 95 PRX 18, 95 REC 18, 95 SX18).

Hauteur jusqu'à 470 m. Puissances jusqu'à 7,5 kW-10HP.

Quantité de sable jusqu'à 300 g/m³ d'eau (série High Capacity jusqu'à 50 g/m³ d'eau, 95 REC - 95 SX - 95 PR 18, 95 PRX 18).



ELECTROBOMBAS SUMERGIDAS ENCAPSULADAS 4" (SERIES 95 PR N/95 PRX N / 95 PRG N)

Las electrobombas sumergidas serie 95 PR N / 95 PRX N / 95 PRG N son las más pequeñas de la extensa gama de fabricación que desde hace 40 años fabrica PANELLI.

El concepto innovador del rodete flotante favorece el flujo de agua en la bomba con importantes ventajas hidráulicas y de funcionamiento.

VENTAJAS

- Elevada eficiencias
- Elevada resistencia a la abrasion por arena
- Durabilidad de vida mas larga gracias a la calidad de los materiales y al concepto de impulsor flotante
- Manutencion minima

MATERIALES

Los materiales en ejecución estandard son los siguientes: Rodete en technopolimero (Lexan) Difusor en technopolimero (Noryl GFN2). Elemento intermedio en Acero Inoxidable AISI 304. Camisa externa en acero Inoxidable AISI 304. Cuerpo de aspiración e impulsión en bronce o en acero inoxidable. Válvula de retención en acero Inoxidable Aisi 304 incorporada en la impulsión de la bomba. Además de los materiales de construcción de serie, las bombas pueden ser fabricadas con el cuerpo de aspiración y el cuerpo de impulsión en micro fundicion de acero inoxidable AISI 304 (SERIES 95 PRX), cuerpo de aspiracion y de impulsión en hierro fundido con cataforesis (95 PRG)

PRESTACIONES HIDRAULICAS

Caudal hasta 24 m³/h gracias a la unicidad de la serie High Capacity (95 PR 18, 95 PRX 18, 95 PRG 18, 95 REC 18, 95 SX18). Altura hasta 470 m. Potencias hasta to 7,5 kW-10HP.

Maxima cantidad de arena hasta 300 g/m³ de agua (serie High Capacity hasta 50 g/m³ de agua, 95 REC - 95 SX - 95 PR 18, 95 PRX 18, 95 PRG 18).



Tolleranze secondo UNI ISO 9906 livello 3B - Tolerances according to UNI ISO 9906 grade 3B

4" 95 PR2 95 PRX2 95 PRG2



CARATTERISTICHE IDRAULICHE - HYDRAULIC PERFORMANCES

Q= Portata - Capacity - Debit **50 Hz n= 2900 min**

Tipo Type	Power		V230 Single Phase		V400 Three Phase A	l/min	0	20	30	40	50	60
	kW	HP	A	µF			l/sec	0,33	0,50	0,67	0,83	1
							m ³ /h	1,2	1,8	2,4	3,0	3,6
95 PR2 N/07	0,37	0,5	3,5	16	-	H(m)	46	40	36	31	24	15
95 PR2 N/10	0,55	0,75	4,9	20	1,7		66	57	52	44	35	22
95 PR2 N/14	0,75	1	6,5	30	2,2		92	80	73	62	49	31
95 PR2 N/21	1,1	1,5	9,4	40	3		138	120	109	93	73	46
95 PR2 N/28	1,5	2	11,5	50	4		184	160	145	124	97	61
95 PR2 N/41	2,2	3	14,7	75	5,7		269	234	213	182	143	90
95 PR2 N/56	3	4	-	-	7,4		368	320	291	248	195	123
95 PR2 N/70	4	5,5	-	-	10		460	400	363	310	243	153

DIMENSIONI D'INGOMBRO E PESI - OVERALL DIMENSIONS AND WEIGHTS

Type	A mm Single Phase V 230	A mm Three Phase V 400	B mm	C mm Single Phase V 230	C mm Three Phase V 400	M Kg Single Phase	M Kg Three Phase	P Kg
95 PR2 N/07	681	-	364	317	-	7	-	4
95 PR2 N/10	767	747	430	337	317	8	8	5
95 PR2 N/14	880	855	518	362	337	10	10	6
95 PR2 N/21	1064	1034	672	392	362	12	12	7
95 PR2 N/28	1248	1218	826	422	392	13	13	9
95 PR2 N/41	1579	1564	1112	467	452	15	15	12
95 PR2 N/56	-	1999	1442	-	557	-	19	16
95 PR2 N/70	-	2347	1750	-	597	-	22	20

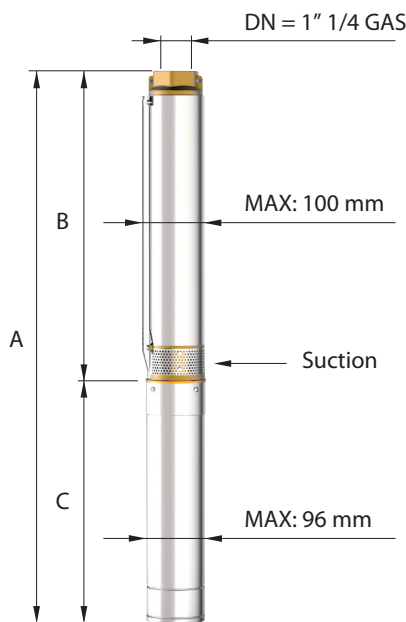

Versioni disponibili
Available versions
Versions disponibles
Versiones disponibles

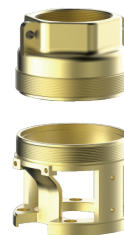

95 PR
Gabbia di aspirazione e mandata in ottone
Suction cage and delivery bowl in brass



95 PRX
Gabbia di aspirazione e mandata in AISI 304 microfuso
Suction cage and delivery bowl in AISI 304 casted



95 PRG
Gabbia di aspirazione e mandata in ghisa con trattamento di cataforesi
Suction cage and delivery bowl in cast iron with CED (Cathode Electro Deposition)

n% = Rendimento della pompa
n% = Rendement de la pompe
n% = Pump efficiency
n% = Rendimiento de la bomba

Max 56 %

kW/st = Assorbimento per stadio
kW/st = Absorption par étage
kW/st = Stage absorption
kW/st = Potencia absorbida por etapa

Max 0,053

Tolleranze secondo UNI ISO 9906 livello 3B - Tolerances according to UNI ISO 9906 grade 3B

tolleranza alla sabbia 300 g/m³ - sand tolerance 300 g/m³

PANELLI®

4"

95 PR2
95 PRX2
95 PRG2

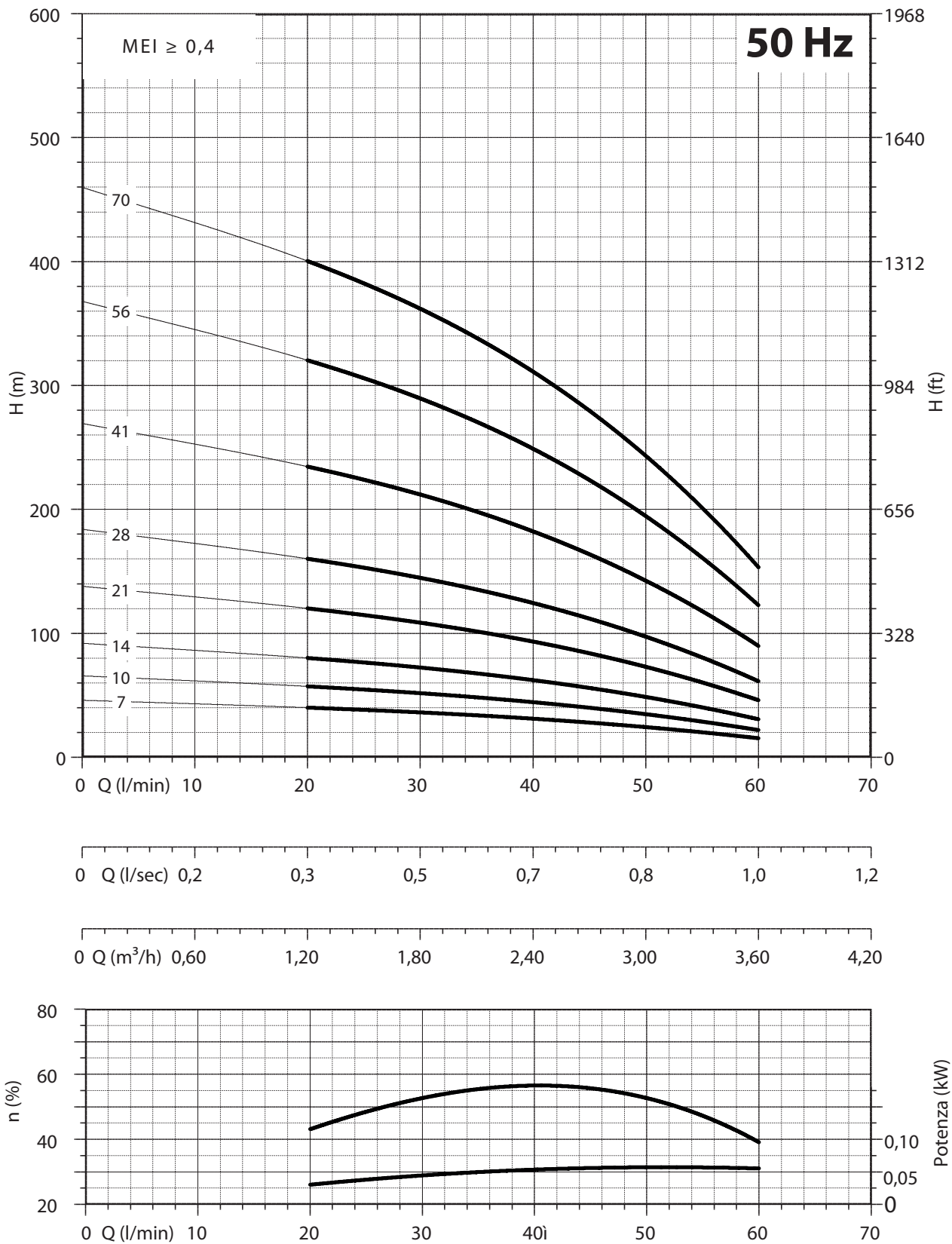

NPSH (m)			25%	50%	75%	100%
95 PR 2	95 PRX 2	95 PRG 2	2	2	2,5	3,2